

XMM-Newton EPIC-pn cross-calibration with *NuSTAR* and *Chandra*

Felix Fürst • 24.04.2023

for the EPIC IDT at the XMM-Newton SOC

Overview

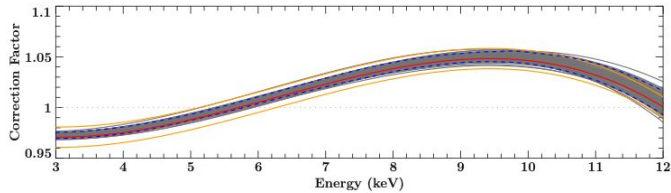

Figure 3: Spline correction function based on modeling of the Crab nebula. Note that the absolute value of the factor is arbitrarily chosen. In red the best-fit is shown, with the $\pm 1\%$ deviation in orange. In gray an ensemble of 100 solutions based on walkers within the 90% contour of an MCMC simulation are shown, with the corresponding 90% quantile of all walkers shown as a blue dashed line.

Status

In April 2022 we published a new CCF to align the pn effective area better with NuSTAR. Corrections need to be activated by the user setting ‘applyabsfluxcorr=yes’ in arfgen.

Corrections are about $\sim 5\%$ at 9keV.

Caveat

Correction only of the shape above 3keV.

No correction of the absolute flux

No correction/information below 3keV

Idea

Include Chandra HETG in the analysis, to tie things to lower energies and check for the absolute flux.

<https://xmmweb.esac.esa.int/docs/documents/CAL-TN-0230-1-3.pdf>

Crab residuals show a “bump”

Data available for observations every ~6 months between 2013-2021.

Fitted with same photon index for pn and *NuSTAR*.

Allowing for different cross-normalizations.

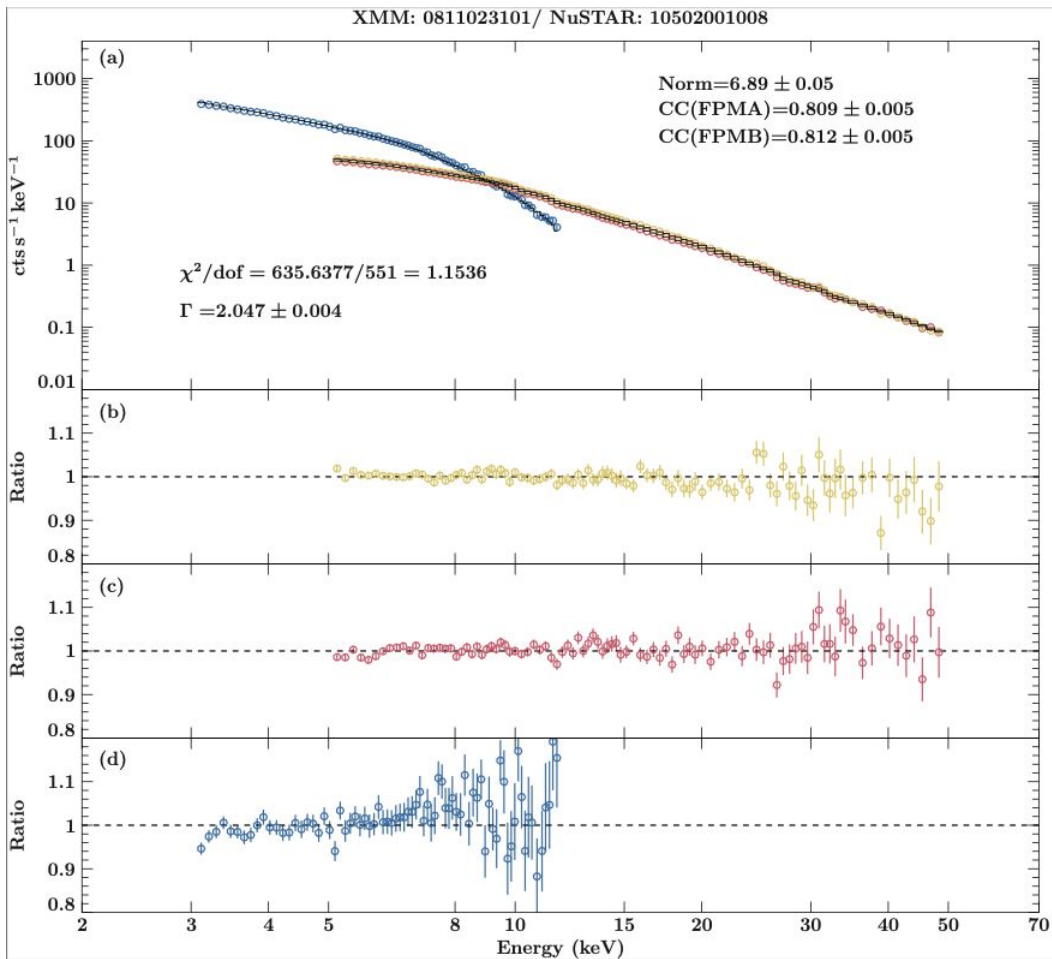

Crab residuals show a “bump”

Stacked residuals of 13 Crab observations between 2013-2021.

Fitted with same photon index for pn and *NuSTAR*.

Correct these residuals with a simple spline, anchored at 1keV and 12.5keV.

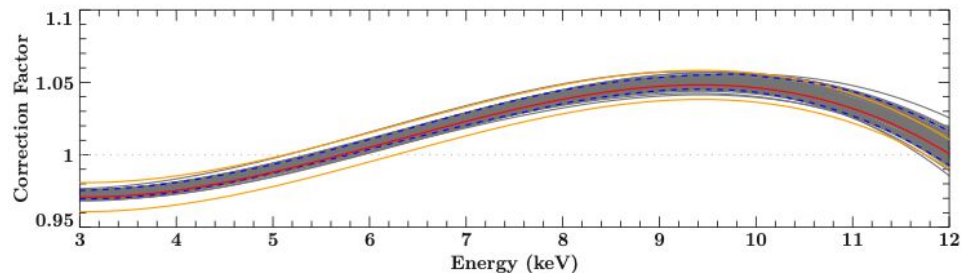

Figure 3: Spline correction function based on modeling of the Crab nebula. Note that the absolute value of the factor is arbitrarily chosen. In red the best-fit is shown, with the $\pm 1\%$ deviation in orange. In gray an ensemble of 100 solutions based on walkers within the 90% contour of an MCMC simulation are shown, with the corresponding 90% quantile of all walkers shown as a blue dashed line.

AGN Small Window mode Test Sample

Table 4: List of observations used to test the new correction function. All EPIC-pn data were taken in Small Window mode. The last two columns give the best-fit χ^2 value for the uncorrected (base) and corrected data, respectively.

Source	XMM ObsID	NuSTAR ObsID	χ^2_{base}	χ^2_{corr}
NGC 4593	0740920401	60001149006	215.63	216.78
3C120	0693781601	60001042002	286.93	300.55
HE 1136-2304	0741260101	80002031003	222.71	215.87
MCG-6-30-15	0693781401	60001047005	257.04	257.32
HE 1143-1810	0795580101	60302002002	252.38	248.32
HE 1143-1810	0795580201	60302002004	238.57	228.79
HE 1143-1810	0795580501	60302002010	243.22	236.48
Fairall9	0741330101	60001130003	357.50	316.04
MCG-6-30-15	0693781201	60001047002	227.76	219.19
MR2251-178	0763920701	60102025006	263.57	252.70
MR2251-178	0763920801	60102025008	263.70	242.44
MR2251-178	0763920601	60102025004	1550.95	234.60
HE 1143-1810	0795580301	60302002006	259.77	256.14
Swift J2127.4+5654	0693781701	60001110002	236.79	230.14
RXS J1131-1231	0820830101	60401001002	230.55	230.79
Swift J2127.4+5654	0693781901	60001110007	291.14	284.86
MCG-6-30-15	0693781301	60001047003	274.36	254.56
IRAS 09149-6206	0830490101	60401020002	190.32	196.22
ESO511-G030	0852010301	60502035006	239.79	232.78
NGC4151	0679780301	60001111005	327.58	308.40
Mrk359	0830550901	60402021004	231.18	228.56
3C382	0790600201	60202015004	285.77	274.95

Sample based on previous work by Andrea Gokus and Amy Joyce.

All source rigorously checked for pile-up and variability (requiring strictly simultaneous GTIs).

Sources fit with best fit phenomenological model, based on Andrea's and Amy's work.

Test with AGN/Small Window sample

No correction

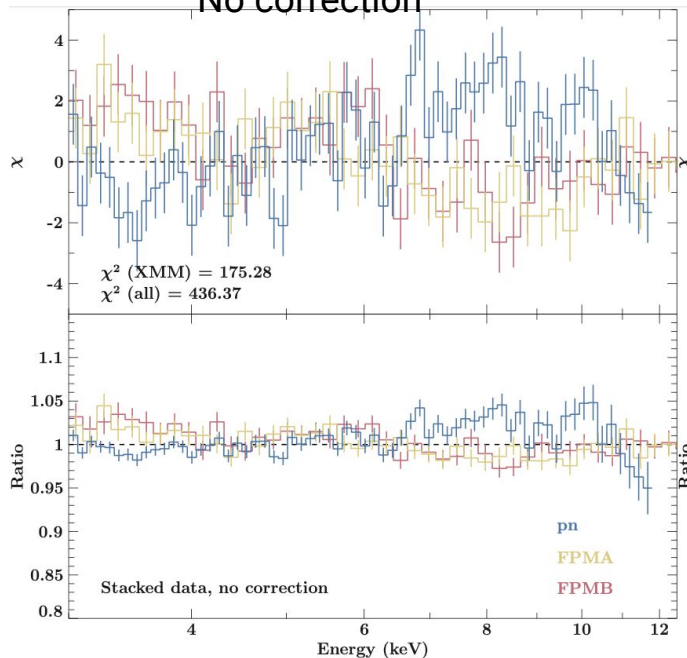

With correction

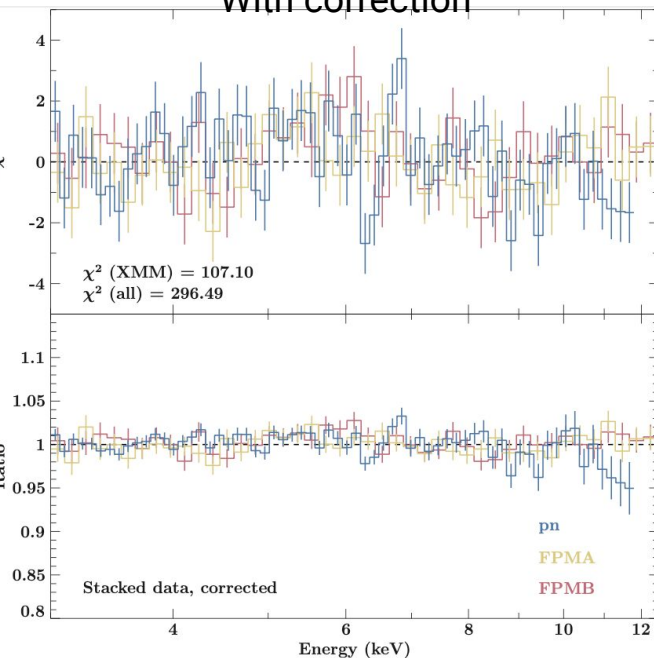

All fitted individually,
simultaneous for
NuSTAR and EPIC-pn.

**Allowed for a free cross
calibration.**

Showing stacked
residuals (χ^2 and ratio).

New data since release of CCF in
2022



Monitoring the correction based on Crab spectra

15 datasets available for observations every ~6 months between 2013-2023.

Fitted with same photon index for pn and *NuSTAR*.

Made sure extraction region has the same footprint on the sky.

Allowing for different cross-normalizations.

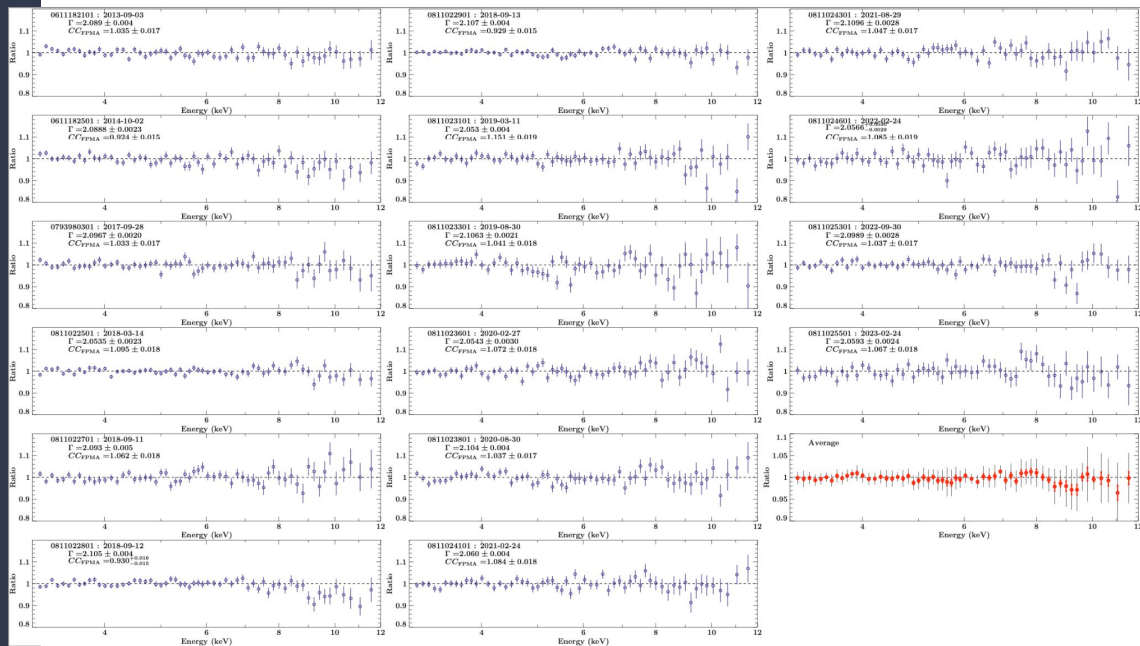

Monitoring the correction based on Crab spectra

15 datasets available for observations every ~6 months between 2013-2023.

Fitted with same photon index for pn and *NuSTAR*.

Made sure extraction region has the same footprint on the sky.

Allowing for different cross-normalizations.

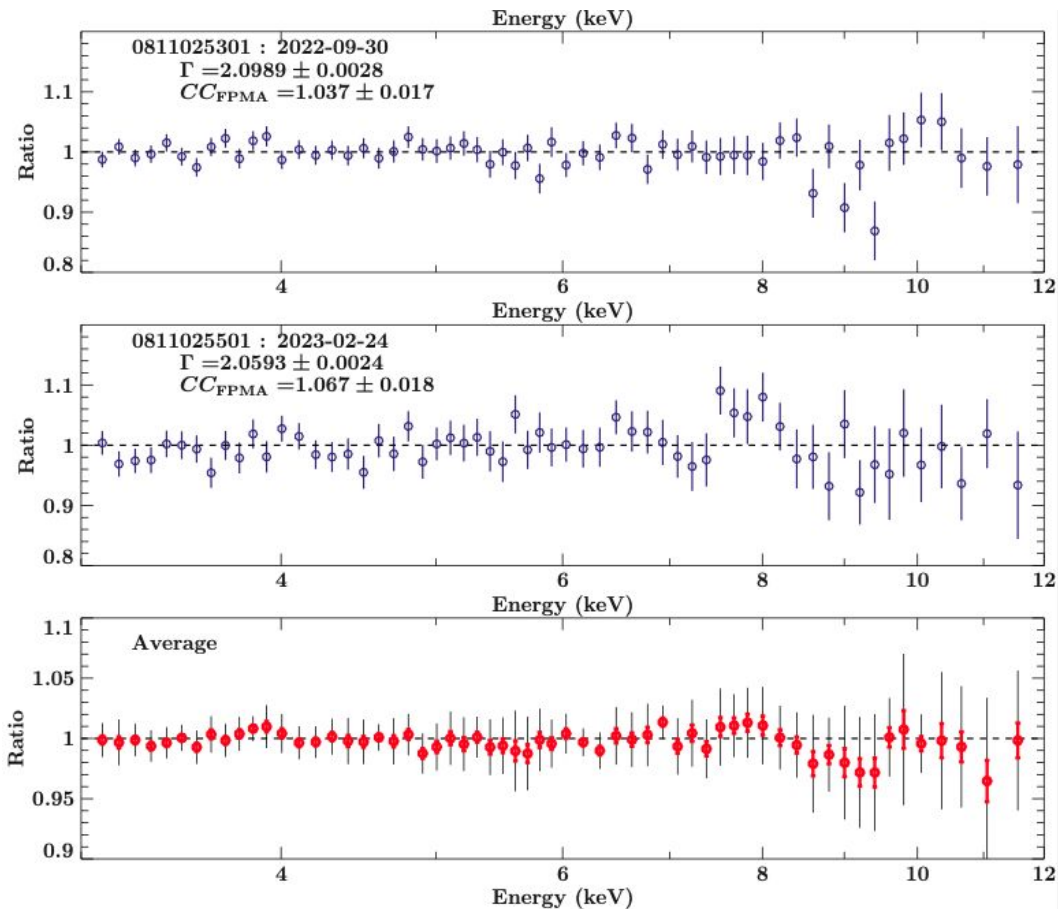

Crab residuals show a “bump”

Stacked residuals of 15 Crab observations between 2013-2023.

Fitted with same photon index for pn and *NuSTAR*.

Correct these residuals with a simple spline, anchored at 1keV and 12.5keV.

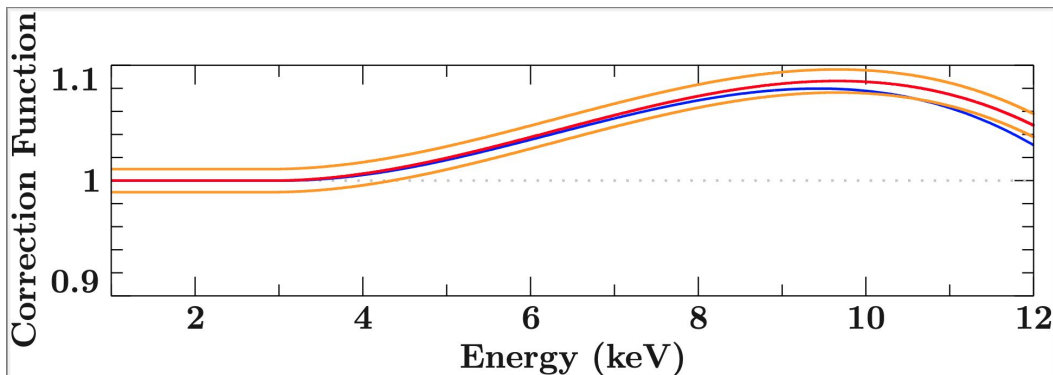

Correction function from the CCF (published) in **red**, with +/-1% range in **orange**.

New correction function in **blue**.

Differences only appreciable >10keV, but no uncertainties analysis performed yet.

Crab spectra with current correction.

Re-extracted all data with 'applyabsfluxcorr=yes' and performed same fit method.

In particular, photon index across all instruments is fixed!

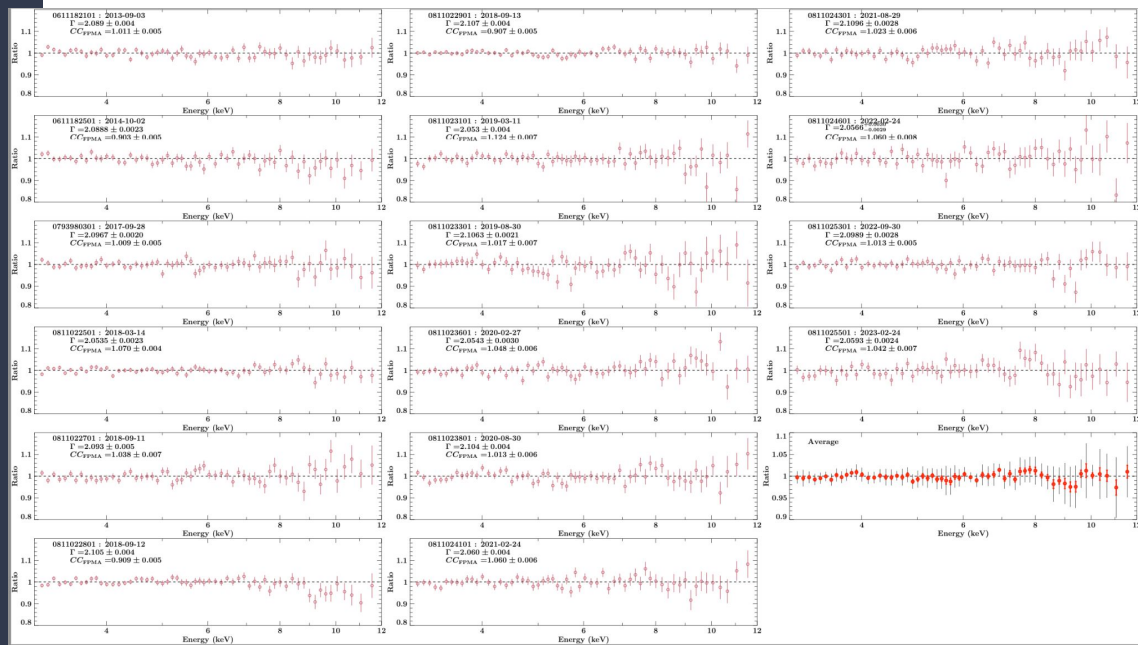

Crab spectra with current correction.

Re-extracted all data with
'applyabsfluxcorr=yes' and
performed same fit method.

In particular, photon index across all
instruments is fixed!

Currently no update on CCF planned or
needed.

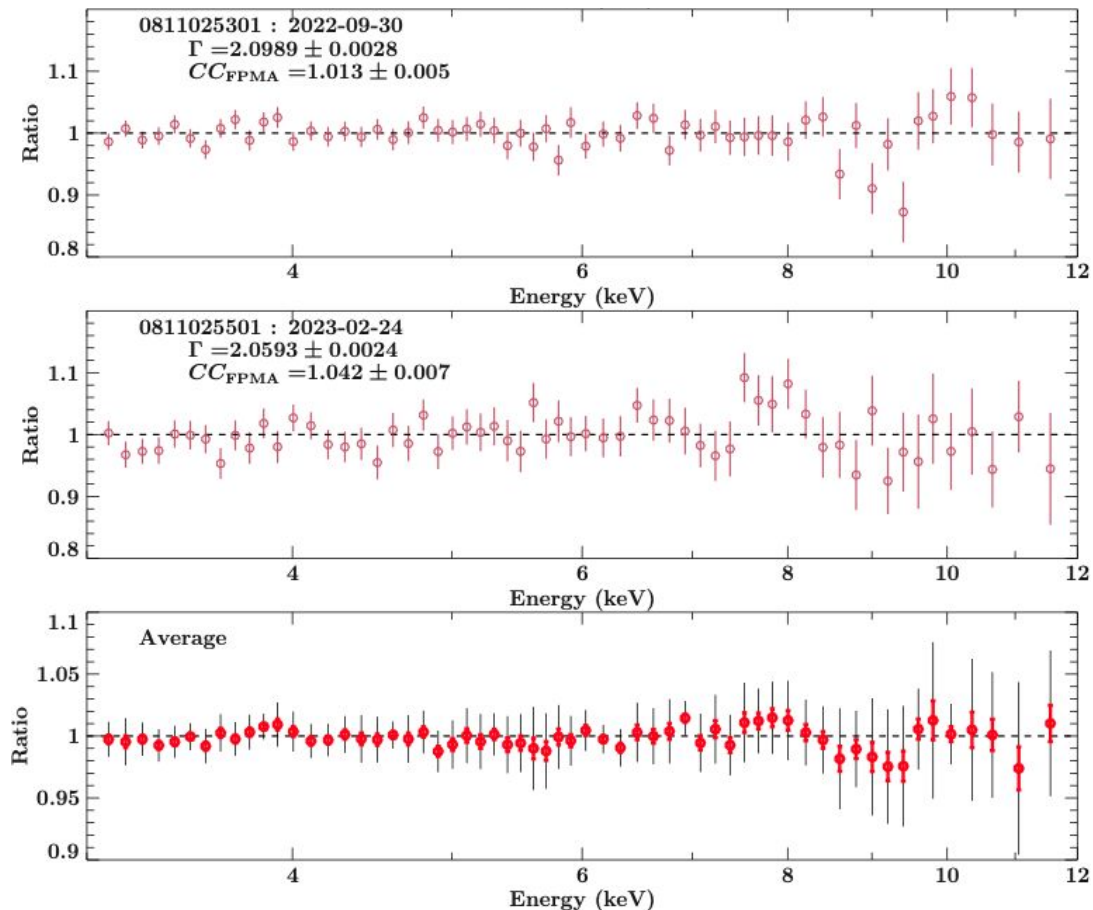

CCF corrections still work very well!

3C 273, now including Chandra

Table 2: Observation Log for the 3C273 observations.

Date	EPIC-pn	ObsID		Exposure [ks]			Fit Par Γ
		NuSTAR	Chandra	EPIC-pn	NuSTAR	Chandra	
2012-07-16	0414191001	10002020001	14455	16.50	12.18	24.15	$1.634^{+0.010}_{-0.011}$
2015-07-13	0414191101	10002020003	17393	20.60	16.31	29.24	$1.651^{+0.013}_{-0.014}$
2016-06-26	0414191201	10202020002	18421	20.81	15.07	29.20	1.488 ± 0.009
2017-06-26	0414191301	10302020002	19867	18.63	13.35	26.26	$1.542^{+0.013}_{-0.014}$
2018-07-04	0414191401	10402020006	20709	18.75	13.07	26.95	1.646 ± 0.016
2019-07-02	0810820101	10502620002	21815	19.99	15.08	28.27	$1.695^{+0.015}_{-0.016}$
2020-07-06	0810821501	10602606002	22828	19.42	13.69	27.77	1.640 ± 0.012
2022-06-28	0810821901	10802608002	25691	20.78	14.94	29.16	$1.657^{+0.012}_{-0.013}$

3C 273 as second big calibration source, but spectrum much more complicated than that of the Crab.

But spectral fits show same residuals as in the Crab, and are solved by same correction function!

Adding Chandra to test corrections at energies <3keV.

Apply Correction to 3C 273 with HETG data

8 epochs of 3C 273 data between 2012-2022 (2021 missing due to some issues with the observation)

Fitted with `cutoffpl + diskbb + xillver` (`xillver` normalization fixed in all epochs, distant reflection, see Madsen et al. 2015).

Using “`applyabsflux=yes`” to see the effect of the updated calibration.

Using HEG +/-1 and MEG +/-1 combined.

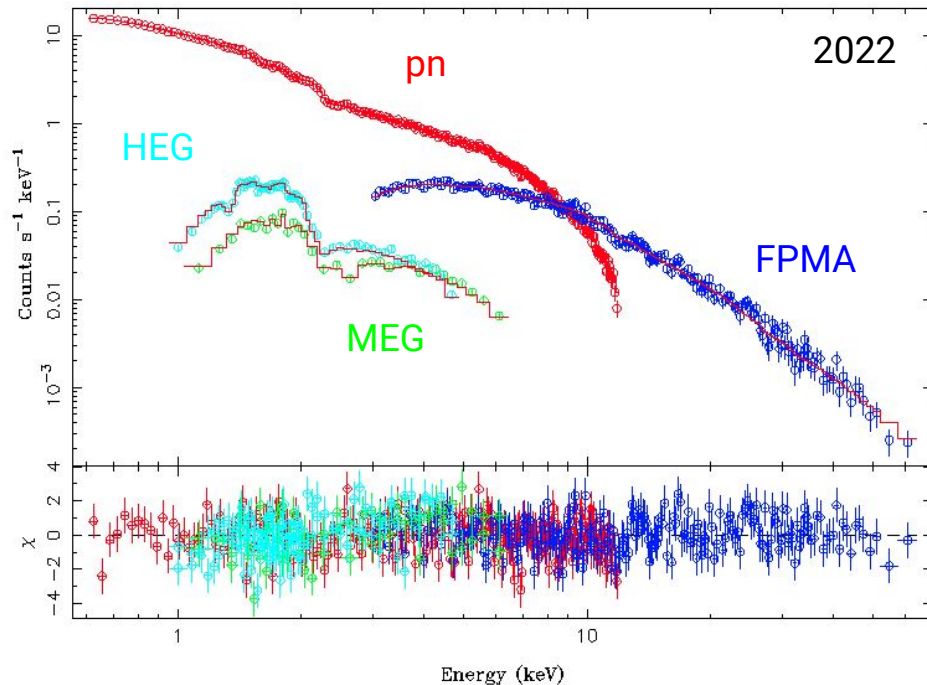

pn residuals

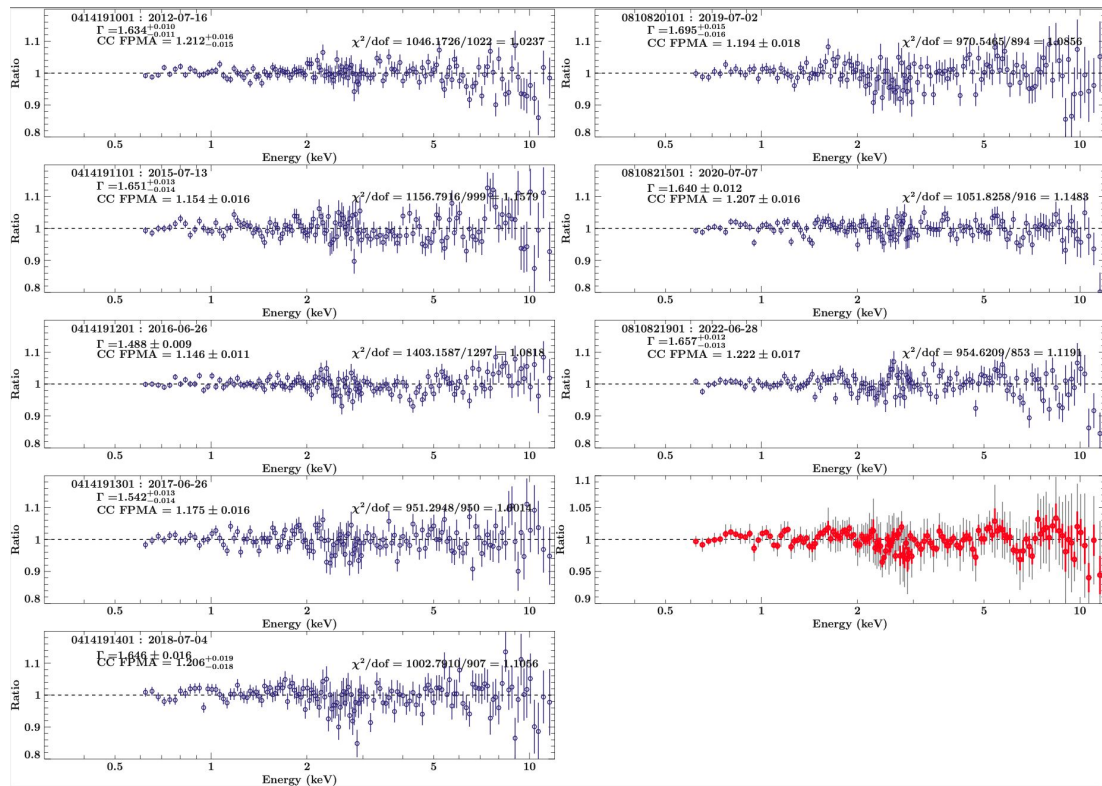

No strong systematic residuals after correction is applied.

Photon-index driven by high energy NuSTAR data.

Low energies dominated by 'diskbb' component that does not show up in NuSTAR.

FPMA residuals

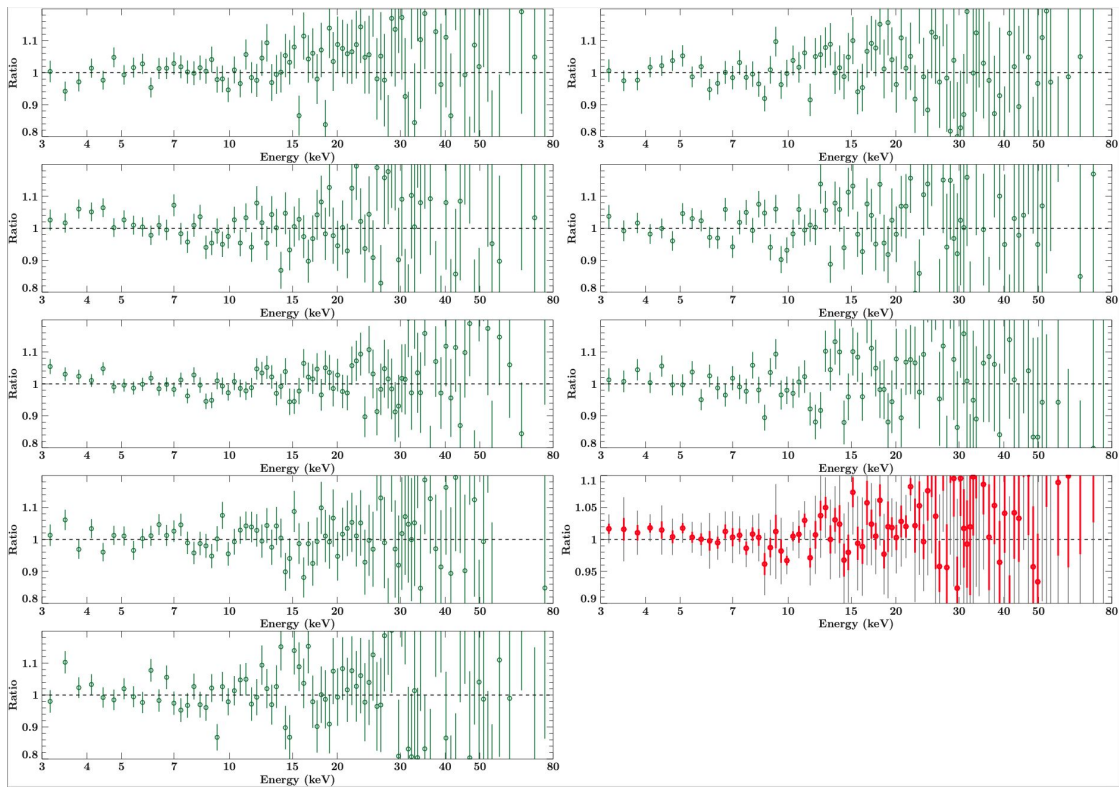

No strong systematic residuals after correction is applied.

Photon-index drive by high energy NuSTAR data.

Low energies dominated by 'diskbb' component that does not show up in NuSTAR.

HEG residuals

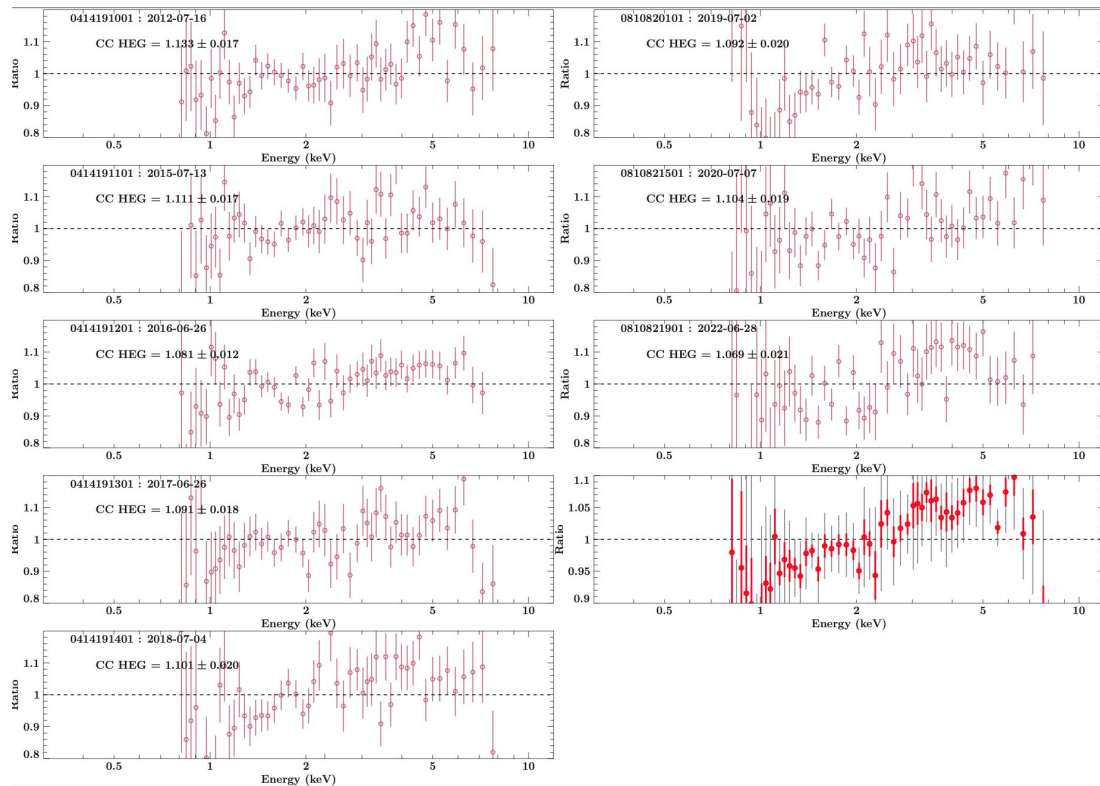

Clear difference in spectral slope is evident (HEG seems to require harder spectrum than pn).

All combined residuals

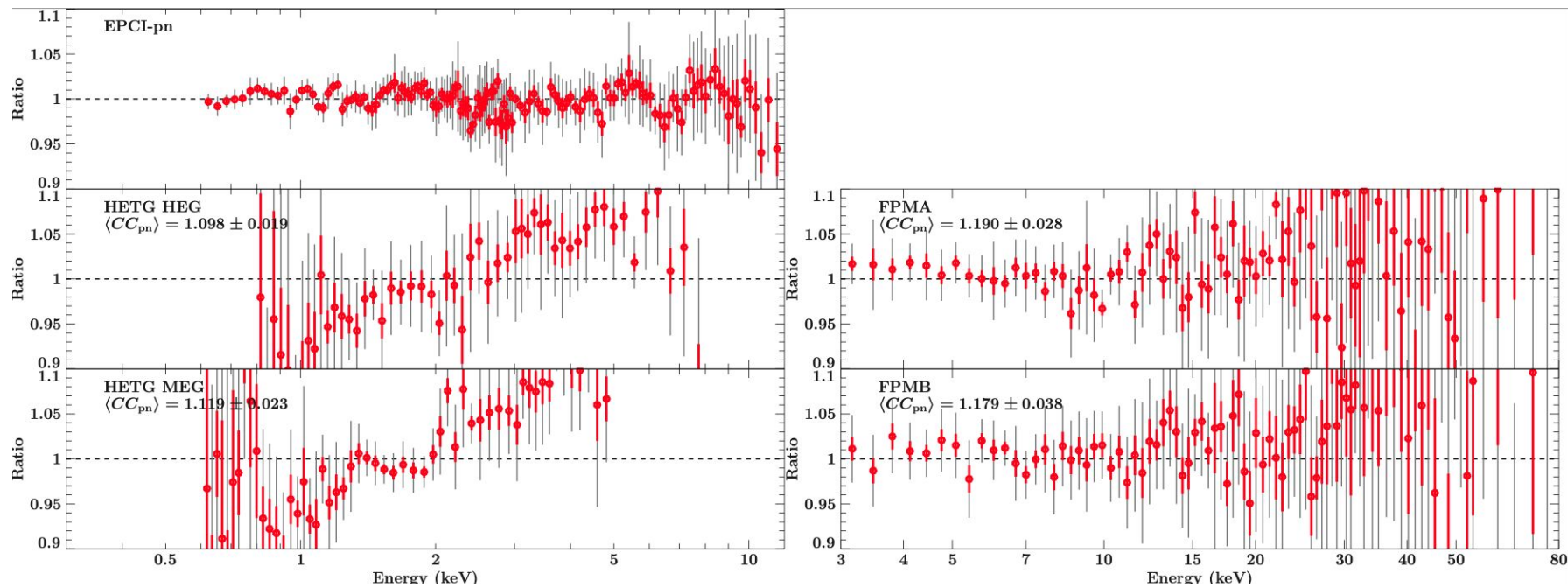

Chandra/HETG impact

- We find a clear disagreement in slope and flux between NuSTAR, pn, and HETG
- NuSTAR and pn agree well, based on the empirical corrections
- Both HEG and MEG require harder spectra
- Both HEG and MEG absolute flux falls between pn and NuSTAR (pn = 1.0, HEG/MEG ~ 1.1, NuSTAR ~ 1.2)

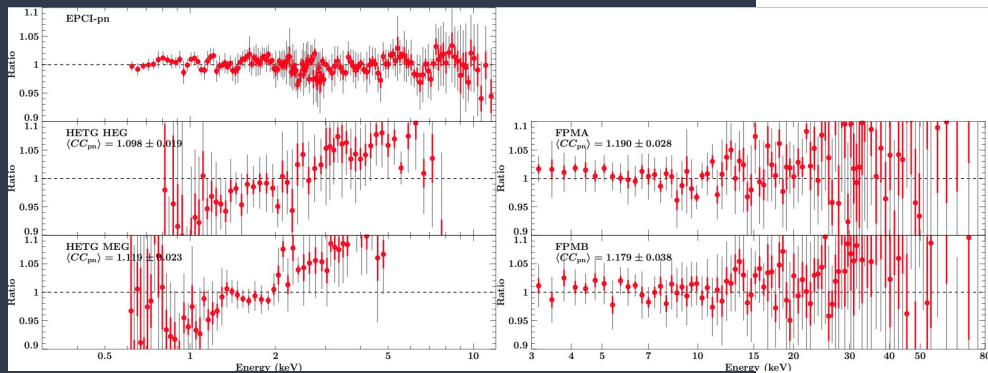

Checked influence of thermal disk component at low energies, but does not change the discrepancy between pn and HETG. Results confirmed my Michael's flux band analysis.

Conclusion and open questions

How can we proceed from here?

Chandra/HETG shows apparent disagreement in both, flux and slope.

Because of that, and degeneracy between them, it is hard to judge which parameter is mostly driving the difference.

Any ideas welcome on how to proceed from here (besides adding more datasets, which is on the agenda).

Goal

We wanted to use Chandra as a gauge for the absolute flux calibration; now we see it falls right between pn and NuSTAR

Changing effective area of EPIC by $\sim 10\%$ is more reasonable than $\sim 20\%$. Still investigating ideas how such a change in effective area could be feasible (e.g., PSF updates).

Appendix



Without diskbb & soft energies

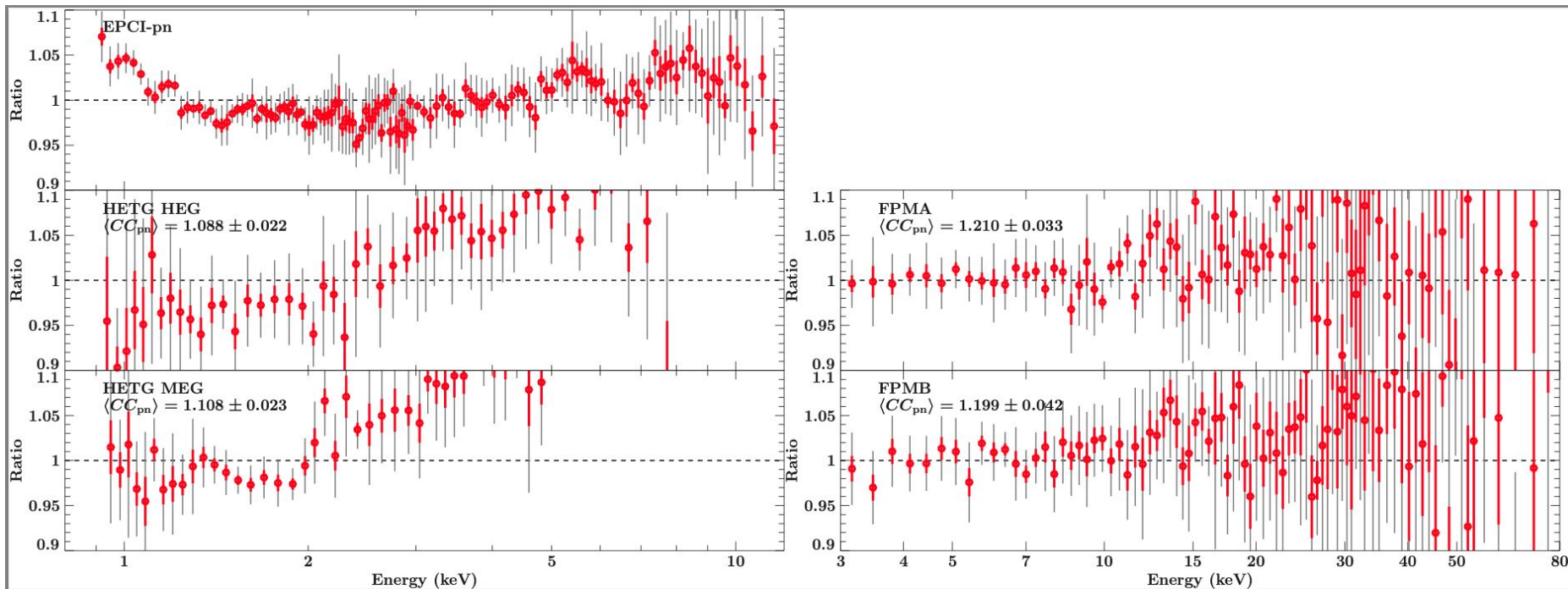

Fit without pn, without diskbb

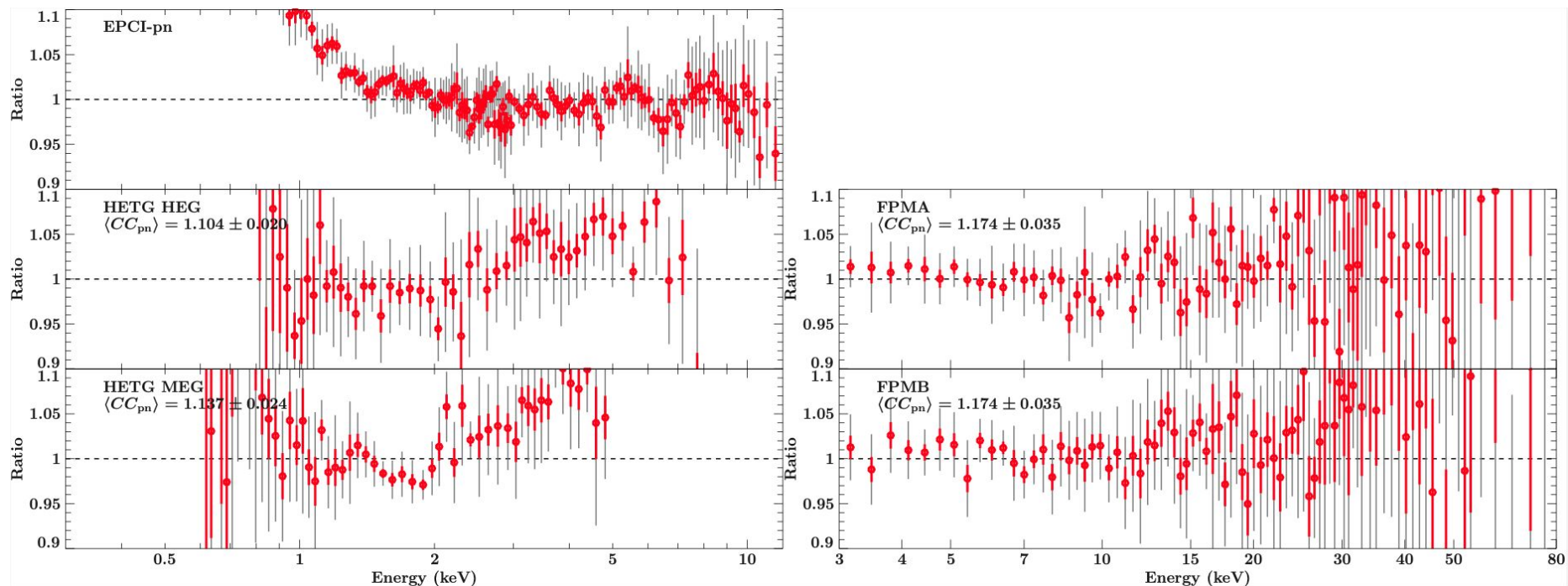

Test and checks

Full Frame mode Test Sample

Target	XMM ObsID	NuSTAR ObsID	χ^2_{base}	χ^2_{corr}
NGC 1313	0693851201	30002035004	247.55	241.06
IRAS 00521-7054	0795630201	60301029004	242.55	242.55
NGC 4579	0790840201	60201051002	237.82	240.79
CEN X-4	0692790201	30001004002	157.64	156.38
HOLMBERG II X-1	0724810301	30001031005	157.97	158.08
NGC 7090 ULX2	0852050201	80501321002	151.11	151.93
M33 FIELD-2	0800350201	50310002003	150.70	150.57
NGC 1313	0693850501	30002035002	172.35	171.54
M33 FIELD-1	0800350101	50310001004	205.71	204.93
RX J0134.2-4258	0841800201	60501005002	149.98	149.42
ELIAS 29	0800030901	30301001004	151.76	150.01
NGC 1313 X-1	0803990101	30302016002	218.58	218.63
NGC7793 P13	0804670301	30302005002	196.21	193.75
MKN 335	0780500301	80201001002	224.87	223.42
NGC 1313 X-1	0803990601	30302016010	223.06	226.62
HESS J1713-381	0790870201	30201031002	171.40	174.49
IRAS 13197-1627	0763220201	60101020002	312.60	314.37
NGC7793 P13	0804670701	30302005004	178.93	174.06
NGC 1313 X-1	0794580601	90201050002	189.45	191.18
NGC 1313 X-1	0742590301	80001032002	184.97	189.07
NUSTARJ150645+0346.2	0795670101	60301023002	212.49	205.56
NGC 1052	0790980101	60201056002	229.61	227.57
NGC 1194	0852200101	60501011002	248.79	251.82
NGC5907 ULX1	0729561301	80001042002	180.99	183.14
ESO 112-G006	0852180101	60561038002	178.58	178.68
CGCG 475-040	0852181001	60561047002	239.28	240.21
NGC 3081	0852180701	60561044002	288.39	282.98
MGC-07-03-00	0852180201	60561039002	198.14	199.47
ESO 426-G002	0852180301	60561040002	229.07	229.41
NGC 5907 ULX-1	0804091101	30302004008	209.10	206.79
ESO 565-G019	0852180601	60561043002	209.15	208.77
NGC 4785	0743010101	60001143002	206.46	208.11
NGC 6552	0852180901	60561046002	206.08	205.99
ESO 116-18	0795680201	60301027002	227.13	222.70
CXOJ022727.5+333443	0784510301	30201003002	191.64	194.58

Long list of diverse source population in Full Frame mode.

All source rigorously checked for pile-up and variability (requiring strictly simultaneous GTIs).

Full frame mode test sample

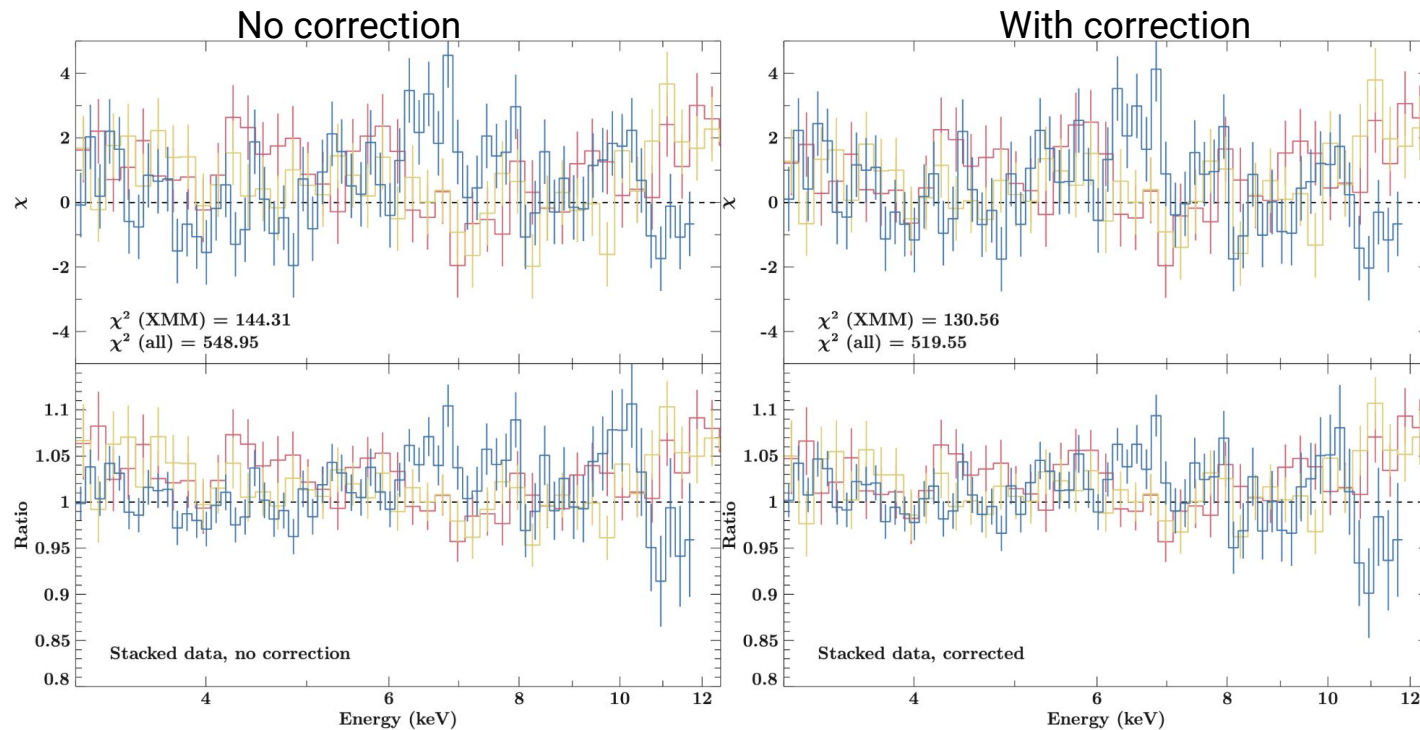

Absolute flux calibration

Current situation (before Oct 2021)

EPIC-pn fluxes are typically 10%-15% **lower** than *NuSTAR* fluxes.

See also IACHEC paper
(Madsen et al., 2017a)

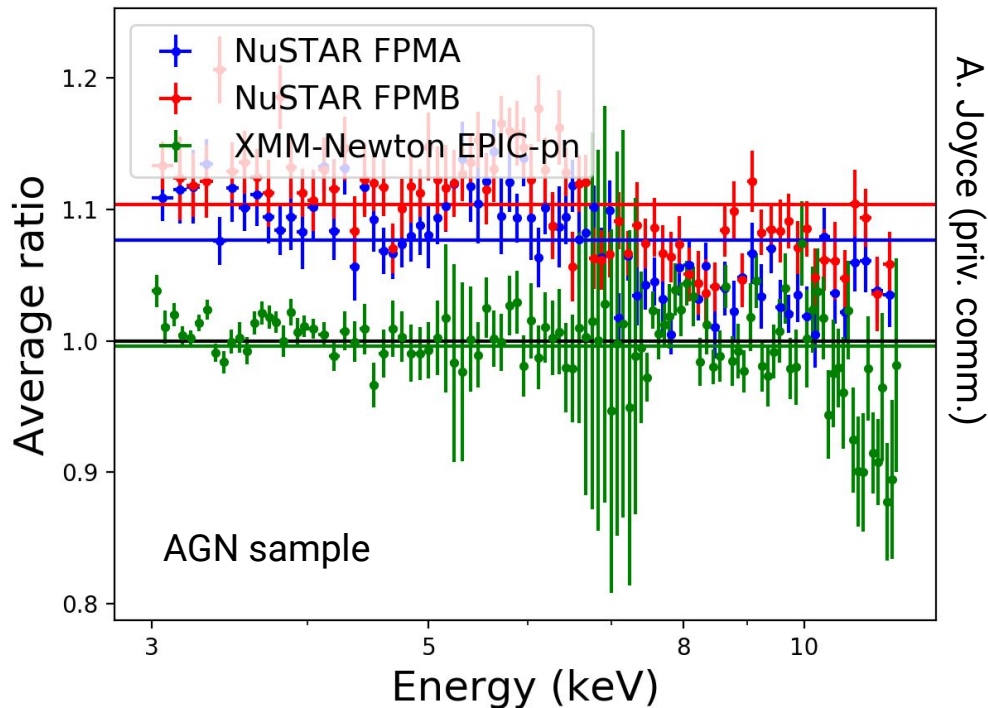
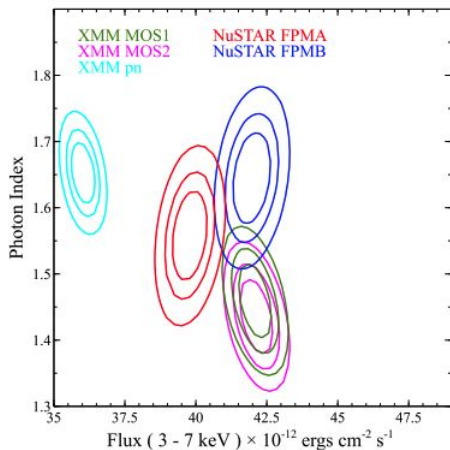

NuSTAR's new effective area

New *NuSTAR* calibration (from October 2021) **reduced** the effective area by $\sim 10\%$.

This change is based on comparisons with stray light observations of the Crab (absolute Crab flux) and better understanding of the detector.

This moves *NuSTAR* fluxes **further away** from *XMM-Newton*/EPIC-pn!

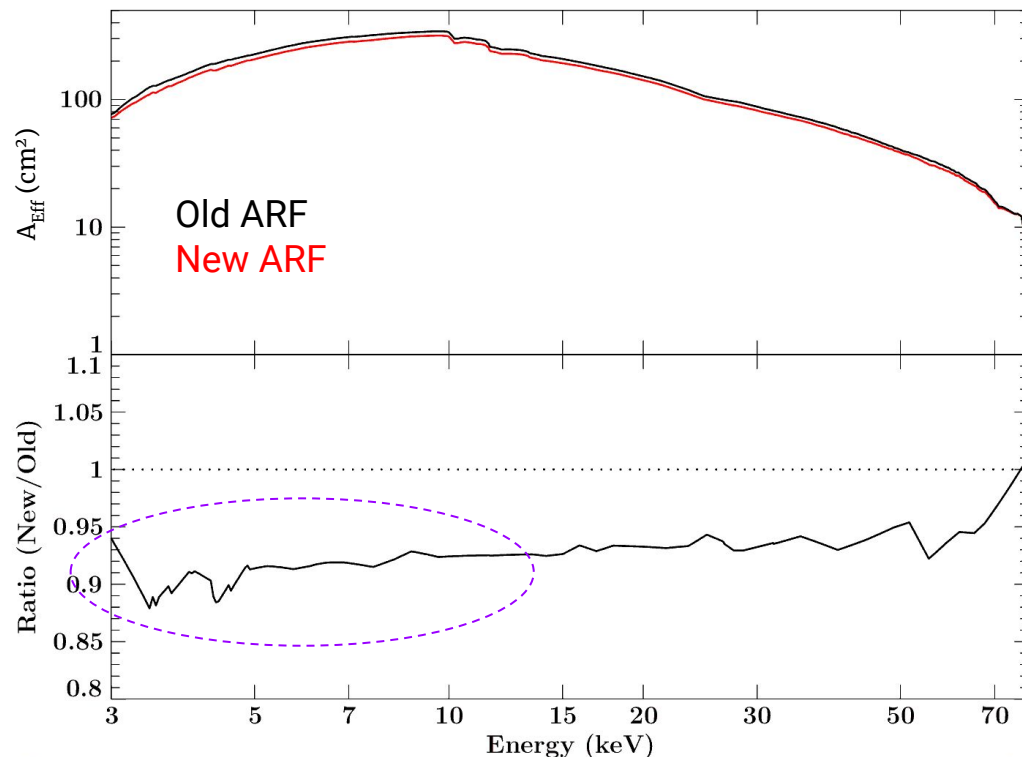

Test with AGN/Small Window sample

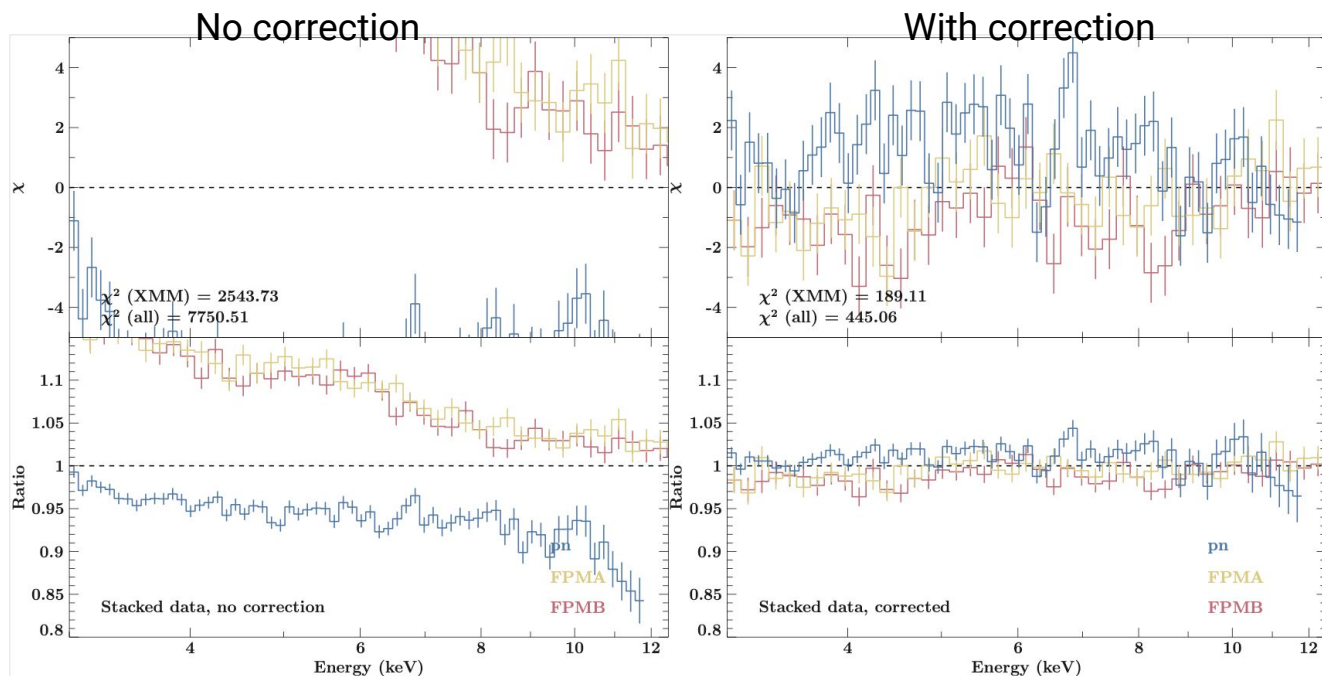

All fitted individually,
simultaneous for
NuSTAR and EPIC-pn.

**Cross calibration fixed
at 1.**

Showing stacked
residuals (χ^2 and ratio).

Very large difference in absolute flux

- *NuSTAR*'s measurement of off-axis Crab are in line with historic measurements
- *NuSTAR*'s new ARF implies a 18% difference to EPIC-pn in the 3-12keV band
- Physical reason for a 18% change of EPIC-pn ARF unknown
- Implications below 3keV cannot be tested with *NuSTAR*

Crab is extended

EPIC-pn is operated in burst mode.

We need to make sure that *NuSTAR* data is extracted from same source region as CCD4 pn footprint on the sky.

Seasonal change between Northern and Southern are of the remnant.

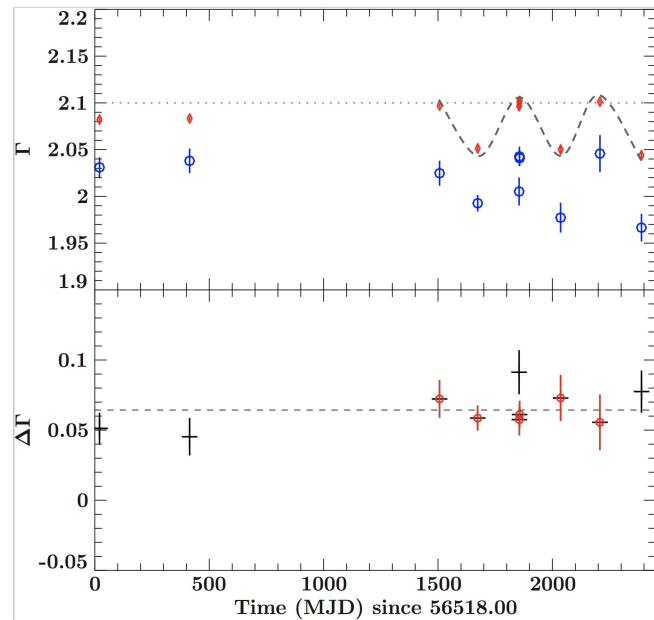
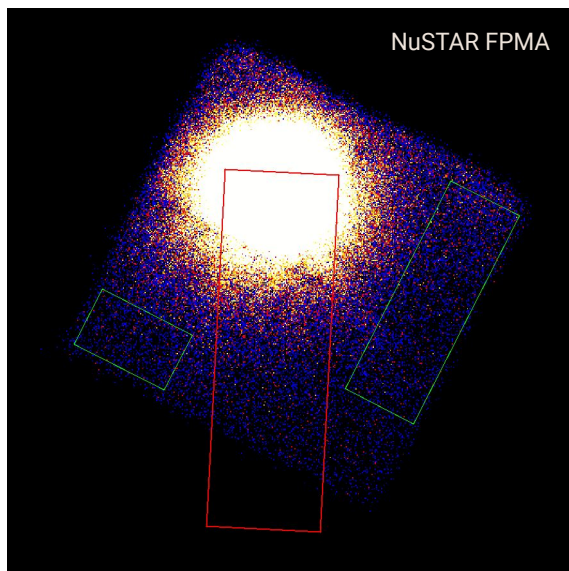

NuSTAR calibration update

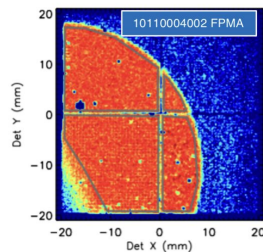
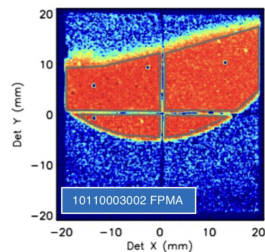
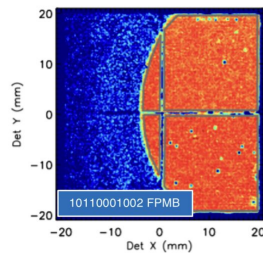
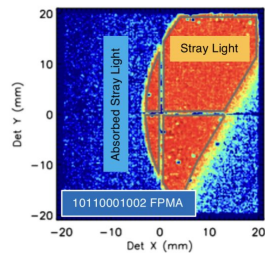
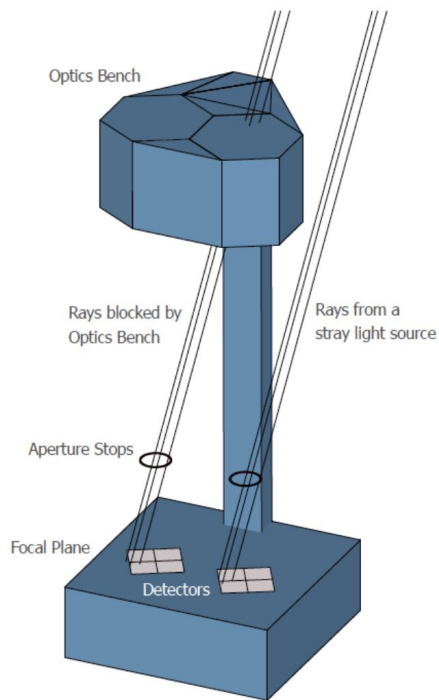

NuSTAR calibration update in **October 2021**.

Based on “stray light observations” of the Crab, avoiding the uncertainties of the optics.

Only need to know photon response of the detector, which is well calibrated from on-ground calibration.

Updated correction function – shape

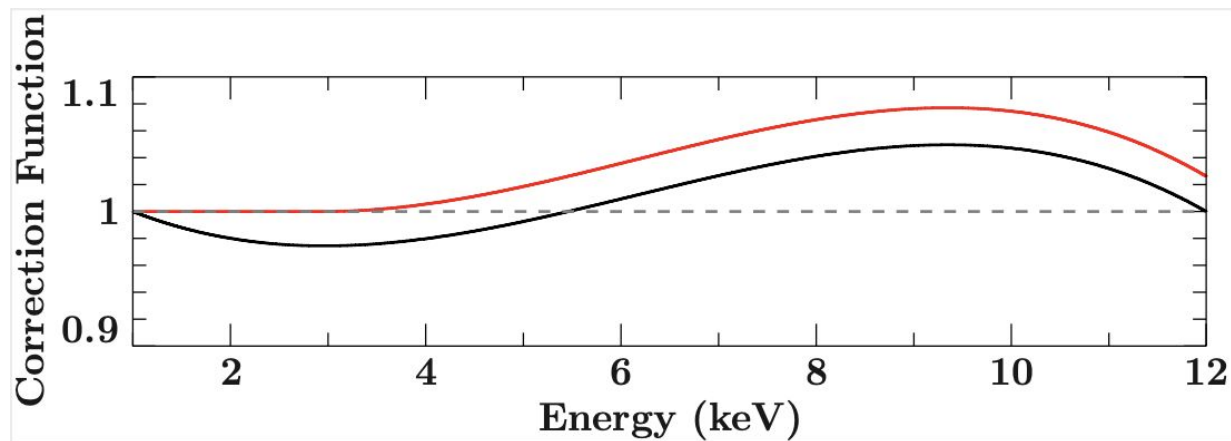

Based on Crab simultaneous observations.

Red line is moved so that below 3keV we have no correction.

This is implemented in
XRT3_XAREAEFF_14.CCF

Next source: 1ES 0229+200

As a possible new good calibration source this BL Lac might be perfect:

- Not too bright / not too faint
- Rather hard power law ($\Gamma \sim 1.8$)
- Simple spectrum (power-law or log-parabola)
- Can even be extended down to UV wavelengths!

Existing data not simultaneously (2009 and 2013)

